

Haier

2019/2020



WHITE GOODS





2019/2020
WHITE GOODS

Haier Europe Trading S.r.l.
3-5 rue des Graviers
92200 Neuilly sur Seine - France
+33 (0)1 73 79 48 00

haier.com   

Images are for reference only and are subject to change without prior notice .

Haier

Haier

2019/2020

WHITE GOODS





Haier

2019/2020

WHITE GOODS

Haier Europe Trading S.r.l.
3-5 rue des Graviers
92200 Neuilly sur Seine - France
+33 (0)1 73 79 48 00

haier.com   

Images are for reference only and are subject to change without prior notice .

WHO WE ARE

CLOSE TO OUR CUSTOMERS

For more than 30 years, Haier has devoted its energy and expertise to developing the best appliances in order to satisfy our most discerning customers.

Since its creation in 1984, the company has been run by the same CEO, Zhang Ruimin, who has always had a clear objective: to build high-quality, reliable products. Within the first year of his appointment, in response to complaints about faulty fridges, his radical action of smashing the fridges with a hammer in front of employees has been recognised as an important cornerstone of the brand.

Since then, the company has evolved with the changing requirements of the modern world and of today's consumer, capitalising on its core values of quality and reliability to offer premium, innovative and modern products.

We understand that it's only by being close to our customers and by listening to their needs and desires that we can make their lives easier. Our commitment to continually update and expand our product range has made us a life partner of our customers and the worldwide number one home appliances brand for ten years running.



N°1 HOME APPLIANCES GROUP WORLDWIDE WITH 15.4% M/S.



Source: Euromonitor International Limited 2019, % in unit share, 2018 data.

WHAT WE BELIEVE

OUR BEST RESEARCH CENTER IS OUR CUSTOMER'S HOME

At Haier, our aim is to deliver premium-quality, state-of-the-art products that respond to the constantly changing needs of the modern home, ultimately giving consumers more time to do the things that matter to them.

In order to ensure we are responding to real consumer needs, we believe that the home should be the primary research center. Only in real homes can we observe and truly understand consumers' constantly changing domestic habits and demands. Through this closeness, Haier is able to maintain "Zero Distance" between our engineers' innovations and our consumers' lives.

By placing the focus on the home in this way, we're able to fulfill our ultimate aim: giving our customers more time to do the things that matter to them. Our products, built with premium materials by highly-skilled engineers, contain the very latest innovations in technology that have been designed to make them easy to use, efficient and, in the end, time-saving.

We have R&D centres on all five continents of the world whose sole mission is to create the solutions that will give our customers their precious time back. It's why 4% of our turnover is reinvested in innovation alone.

Our Zero Distance approach is what ensures we are constantly able to provide our customers with products that help them with the evolving necessities of daily life. It is through this philosophy that we're able to continually develop our product range and make sure that it can adapt to the ever-changing rhythms of the modern home.



WHERE WE ARE

HAIER IN EUROPE

 +5000 EMPLOYEES

 2 EUROPEAN R&D CENTRES (GERMANY & ITALY)

 PRESENT IN MORE THAN 30 COUNTRIES

 8 EUROPEAN FACTORIES



HAIER EUROPE

Haier Group is the leading white goods producer in the world, with globally recognized brands including Candy, Hoover, GE Appliances and Fisher & Paykel. Haier aims to expand its leadership in smart home appliances in Europe and become consumers' first choice in smart home solutions.

Haier brings manufacturing capabilities in Europe that enable Haier Group to better meet customers' increasingly sophisticated demands for personalized smart products in the new era of the Internet of Things. The acquisition of Candy Group in 2019 means that Haier Group's brands encompass the entire domestic appliances market; from ultra-high premium to more affordable ranges, with quality and an exceptional user experience at the heart of each and every one.



HOW WE COMMUNICATE

ADVERTISING

For its advertising activity, Haier continues to showcase its products within the home environment, emphasizing our **proximity to customers**. Communicating in this manner via major TV, printed and digital media channels is consistent with Haier's philosophy of placing **consumer concerns at the heart of the brand**.



INSTORE ACTIVATIONS

To increase brand awareness and ensure we remain **at the forefront of customers' minds** while making white goods purchases, Haier has used the **'store-within-a-store'** method of communication, featuring **on-site demonstrators** who can explain the many benefits of choosing Haier products for their home.



FAIRS

We present our latest products and innovations every year at fairs such as **Berlin's IFA**, Milan's Eurocucina or Cologne's Living Kitchen, maintaining our position as **world leader in the home appliances market**.





13

REFRIGERATORS

- Xx\ Technologies
- Xx\ Iconic Black
- Xx\ Series 70
- Xx\ Cube Series
- Xx\ French Doors
- Xx\ Side By Side

25

FREEZERS

- Xx\ INSTASWITCH FREEZER
- Xx\ Chest Freezer

31

WINE COOLERS

35

WASHING

- Xx\ Washing Machine
- Xx\ Washer-Dryer
- Xx\ Dryer

49

GLOSSARY



REFRIGERATORS

Xx\ Technologies

Xx\ Iconic Black

Xx\ Series 70

Xx\ Cube Series

Xx\ French Doors

Xx\ Side By Side

Haier's combination of state-of-the-art cooling technology with elegant designs is what makes us a world leader in refrigeration.

It is our focus on innovation that has made it possible to create fridge-freezers with an unparalleled level of food preservation, while still retaining top-tier energy efficiency ratings. For an example of our dedication to new technology, look no further than our game-changing Fresher Techs®. With the Series 70 Fridge-Freezers and French Doors, the flexibility of their cooling technology is matched by the adaptability of their appearance. Equipped with the exclusive Easy Access drawer available in sizes from 60 cm up to 100 cm, we lead the way in convenient and functionally versatile refrigeration. Built to fit seamlessly into your kitchen, we offer high-quality finishes and colours, exemplified by our latest Iconic Black range, the quintessential expression of our ambition to produce the most elegant cooling products.

**Unique designs. Top quality materials.
Innovative technologies.**



FRESHER TECHS®

PRESERVE LIFE'S FLAVOUR



With the aim of revolutionising the kitchen with unprecedented food preservation, Haier has created a series of unique technologies for its cooling range: **Fresher Techs®**.

TECHNOLOGY REFRIGERATORS



FRESHER ZONES



My Zone is an independent compartment that gives you one-touch control over temperature (from -3° to +5°C): QuickCool, Chiller or Fruit & Vegetables.



Instant Cool Zone is both practical and flexible. Controlled by the external display, it cools down beverages in only 20 minutes. The compartment can also be used as a normal fridge zone with a temperature range of 0° to 5°C.

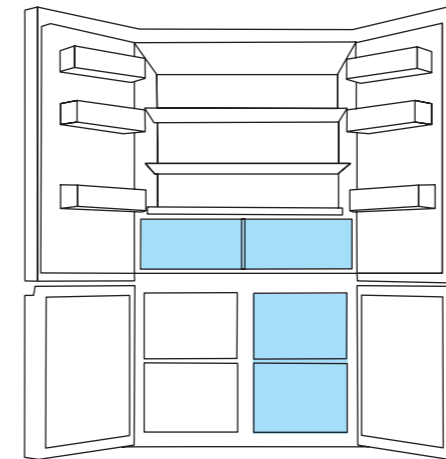
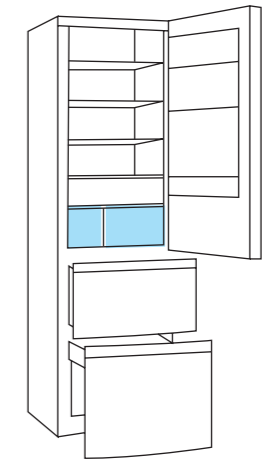

Humidity Zone maintains up to 90% humidity while still allowing air to circulate. This means that you can perfectly preserve the nutritional content of your fruit and vegetables.

Dry Zone reduces humidity to below 45%, which is great for storing dairy products, as well as delicatessen-style prepared foods.



The **Switch Zone**, available in Haier's Cube Series, is a unique compartment that can turn part of your fridge into a freezer (-18°C) or remain as a fridge (+5°). It's like having an extra fridge or freezer!

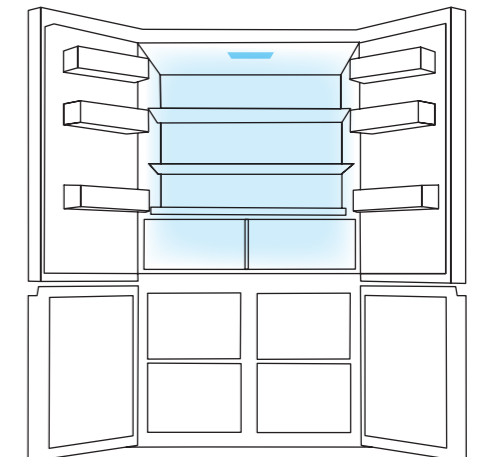

FRESHER FILTERS



ABT® (automatic antibacterial technology) activates a special UV light that eliminates harmful bacteria circulating in the air of your fridge, protecting the taste of your food and the health of your family.

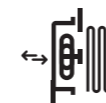

The **Fresher Shield** prevents any variations in temperature by sealing the entire compartment while frost is drained. These stable conditions mean that the original flavour of your groceries is maintained, moisture loss is controlled, nutrients are kept locked-in and energy loss is reduced.

FRESHER PAD

The Fresher Pad is a unique aluminium tray that allows you to speed up the freezing of your stored items. Three times more efficient than similar systems, it helps to preserve the nutritional benefits of frozen food.

FRESHER SENSORS



Fresher Sensors are placed on every shelf to send cooling air only to the part of the fridge that needs it. Newly added items are brought quickly to their optimal temperature, not only preserving the valuable nutrients in fresh food, but also significantly extending its storage life.

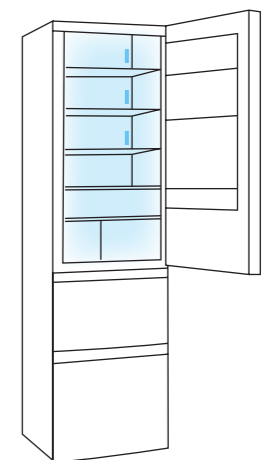

REFRIGERATORS TECHNOLOGY

ICONIC BLACK

THE ESSENCE OF LUXURY

The fashion world knows that black means tasteful class & subtle elegance. The **Iconic Black** is no exception, oozing both in abundance. Understated yet impossible to ignore, it adds a touch of chic to any kitchen. Four layers of stainless steel and coatings mean that not only does the Iconic Black have an eye-catching metallic black lustre that will never fade, but it's also scratch resistant and easy to clean.

ICONIC BLACK
REFRIGERATORS



REFRIGERATORS
ICONIC BLACK

HB26FSNAAA

LIFETIME WARRANTY COMPRESSOR
SWITCH ZONE
DRY ZONES BY FRESHERTECHS



Technical specifications

Energy class	A++
Freezer star rating	*/***
Energy consumption (kWh/year)	435
Net capacity (l)*	685
Net refrigerator capacity (l)*	456
Net freezer capacity (l)	229
Net Switch Zone capacity (l)	-
Freezing power in 24h (kg)	14
Freezer autonomy in case of power cut (h)	24
Climate class	SN-T
Noise level dB (A)	40
Dimensions (cm)	
Height	190
Width	100.5
Depth	76
Net weight (kg)	189
Gross weight (kg)	199

Features

- Dual Inverter, Lifetime Warranty*
- Total No Frost
- LED external control display
- ABT® (antibacterial technology)
- My Zone
- Dry & Humidity Zones
- Super Freezing
- Holiday function
- Day light
- Automatic ice maker
- Eggs tray(s)
- Adjustable feet
- Integrated handles

*Lifetime warranty on compressor only

Black Stainless Steel / Stainless Steel Look
EAN - TBD

HTF-610DSN7

12-YEAR WARRANTY COMPRESSOR
SWITCH ZONE
FRESHERTECHS



Technical specifications

Energy class	A++
Freezer star rating	*/***
Energy consumption (kWh/year)	343
Net capacity (l)*	610
Net refrigerator capacity (l)*	430
Net freezer capacity (l)	90
Net Switch Zone capacity (l)	90
Freezing power in 24h (kg)	10
Freezer autonomy in case of power cut (h)	18
Climate class	SN-T
Noise level dB (A)	40
Dimensions (cm)	
Height	190
Width	90.8
Depth	73.8
Net weight (kg)	133
Gross weight (kg)	145

Features

- Dual Inverter, 12-year Warranty*
- Total No Frost
- LED external control display
- ABT® (antibacterial technology)
- Switch Zone
- Dry & Humidity Zones
- Super Cooling
- Super Freezing
- Holiday function
- Twist ice maker
- Eggs tray(s)
- Adjustable feet
- Integrated handles

*2-year full warranty +10-year compressor only

Black Stainless Steel / Stainless Steel Look
EAN - 6901018069611

HB16WSNAA

A+ ENERGY CLASS
EASY ACCESS DRAWER
TOTAL NO FROST



Technical specifications

Energy class	A+
Freezer star rating	*/***
Energy consumption (kWh/year)	387
Net capacity (l)*	422
Net refrigerator capacity (l)*	301
Net freezer capacity (l)	121
Net Switch Zone capacity (l)	-
Freezing power in 24h (kg)	14
Freezer autonomy in case of power cut (h)	20
Climate class	SN-T
Noise level dB (A)	40
Dimensions (cm)	
Height	190
Width	70
Depth	67.5
Net weight (kg)	95
Gross weight (kg)	103

Features

- Dual Inverter, 12-year Warranty*
- Total No Frost
- LED external control display
- MyZone
- Fast Cooling
- Fast Freeze
- Top LED light
- Ice cube tray(s)
- Eggs tray(s)
- Adjustable feet
- Integrated handles
- Water dispenser

*2-year full warranty +10-year compressor only

Black Stainless Steel / Stainless Steel Look
EAN - 6901018071270

CUBE SERIES

THE REFRIGERATOR THAT PUTS YOU IN COMPLETE CONTROL

To respond to all of your cooling needs, Haier has created a generation of fridge with an adaptable space system: **switch from fridge to freezer and back again!** With specialised drawers and the Dry & Humidity Zones, you'll own a smart fridge that's ready for any situation.

CUBE SERIES
REFRIGERATORS

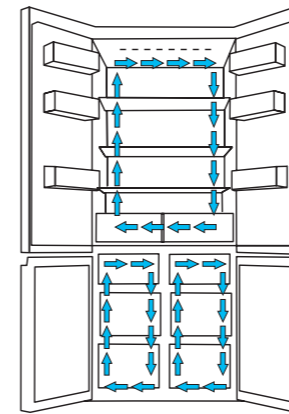

Haier's Cube refrigerators offer infinite possibilities thanks to their unrivalled flexibility. With a refrigerator at the top, a freezer on the bottom left and an ultra-flexible area with temperature regulation on the bottom right.

The **Trilogic refrigeration system** uses three evaporators for a single compressor. The use of a separate evaporator for each compartment ensures that smells and flavours do not mix, keeping the food's optimum flavour from the moment it is stored until it is eaten.

With a **large capacity** of up to 610 litres in the top of the range model, the Cube Series offers spaces which adapt to fit your needs. These multi-door refrigerators store big shops easily and conveniently thanks to their large size, and can also be configured to offer 25% more refrigerator capacity or set up as a refrigerator with two separate freezers.

XXL

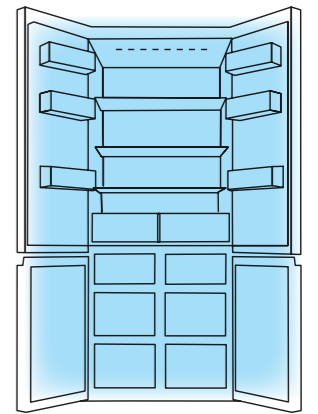

REFRIGERATORS
CUBE SERIES

SMART AND INNOVATIVE DESIGN

Essential to every Cube is its elegant and distinguished style which emphasises the beauty of any kitchen. The modern and unique aesthetic of its four doors, finished in fingerprint-resistant stainless steel, gives a smart and sophisticated look which makes the refrigerator one of the stand-out elements in the room.

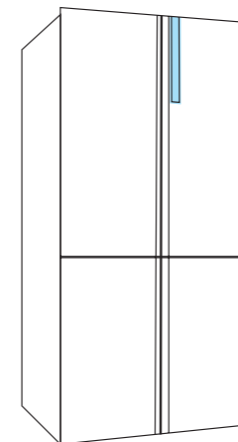

All Haier's Cube models have a modern **digital touch display** which allows you to control the temperature and the refrigerator options from the outside. This avoids the need to keep opening and closing the refrigerator, with the resulting changes in temperature.



Interior LED lighting in the refrigerator and in the freezer to make viewing and access to all the contents easier at any time, night or day.

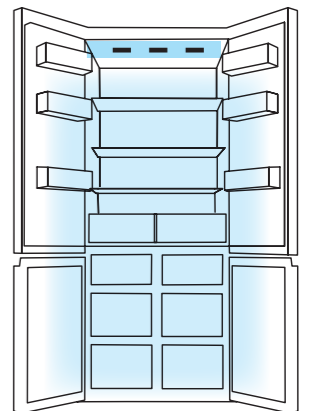

A++ ENERGY RATING. HIGHLY EFFICIENT

A++

Haier's Cube refrigerators offer excellent results in terms of energy efficiency thanks to their A++ rating, which reduces consumption by up to 40% compared to A class models. That means a lower environmental impact and greater savings on bills.

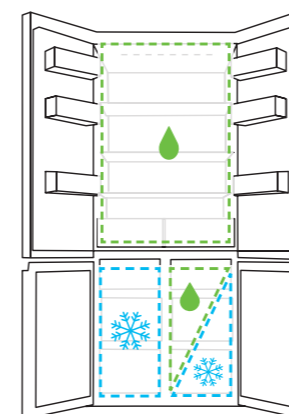

Switch Zone

ABT
Antibacterial
Technology

FRESHER TECHS®

Haier's Cube refrigerators are equipped with some of our Fresher Techs® such as the **Switch Zone**, a unique compartment that can turn part of your fridge into a freezer (-18°C) or remain as a fridge (+5°C), or the **ABT** (antibacterial technology) that eliminates any possible bacteria in the air flow thanks to its UV light.

They also have two special drawers, a **high humidity area** (at 90%) and a **low humidity area** (less than 45%). Ideal for storing and maintaining fresh produce (fruit, vegetables) or dry products (delicatessen, etc) in optimal conditions for longer.

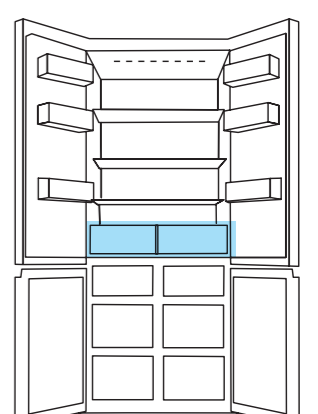

SERIES 70

ALL OF YOUR TREASURES IN ONE GLANCE

Smart, energy-efficient and reliable, **Haier's Series 70 Fridge-Freezer and French Door** are the perfect combination of upmarket design and cutting-edge features. Equipped with our exclusive freezer drawer and Fresher Techs®, there's no need to compromise between freshness & convenience.

SERIES 70 REFRIGERATORS

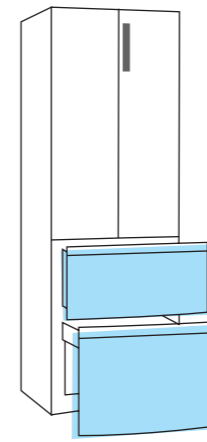

XL

The **Haier Series 70** offers unparalleled cooling storage space for your kitchen. At 70 cm wide and standing at two metres tall, its 470-litre capacity is perfect for keeping larger amounts of food fresher for longer.

Its **Easy Access Drawer** has been specially designed for maximum ease of use. Not only does it allow for a more efficient use of space, it also ensures quick access to the entire freezer for ultimate convenience. Not to mention it can save up to 30% more energy*.

*Tested in real conditions & compared with similar Haier standard fridge-freezer

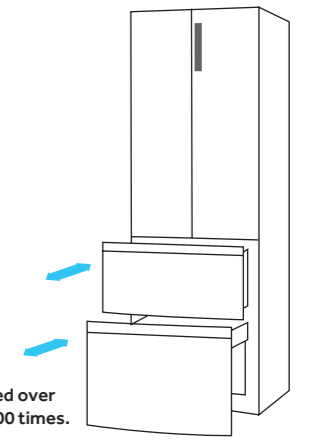

Tested over 50,000 times.

REFRIGERATORS SERIES 70

ENERGY SAVINGS

A++ Haier's Series 70 Fridge-Freezer and French Door have been awarded the A++ energy certification, which means a 20% energy saving compared to the A class. So you can enjoy great performance with low energy consumption*.

*Energy class depending on Series 70 model

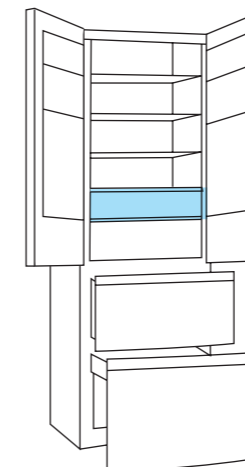

Humidity Zone

The Humidity Zone keeps air moisture levels within the compartment at 90%, while still allowing air to circulate freely. This Fresher Tech® helps to preserve the nutritional content of your fruit and vegetables, which otherwise can be lost due to natural deterioration processes.



MyZone

MyZone is an independent compartment that can be set at various temperatures between -3°C and 5°C, according to your needs. Choose between QuickCool, Chiller or Fruit & Vegetables - it's up to you!

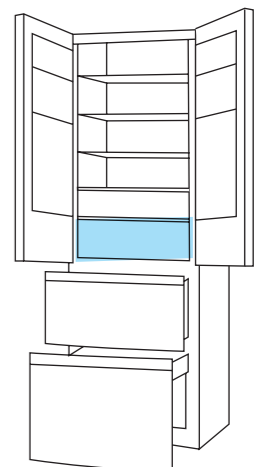

LARGEST RANGE ON THE MARKET

Haier offers the largest range of freezer drawer refrigerators with models available in 60 cm, 70 cm, 83 cm, 90 cm and 100 cm.

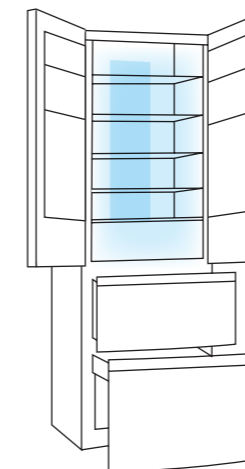

Daylight

The innovative illumination system provides the Series 70 with a bright and brilliant interior light, ensuring enhanced visibility when restocking or removing food. What's more, the Easy Access drawer also includes a light, making it even easier to view what's inside.



Safety glass

Subjected to rigorous testing designed to guarantee reliability, each drawer is also separated by a layer of safety glass. The Easy Access Drawer's exclusive sliding rail system, designed by German company Hettich, has been proven to withstand the wear of opening and closing over 50,000 times. This drawer is an expression of Haier's focus on convenience, efficiency and reliability.

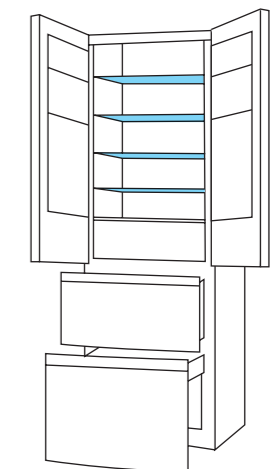

HTF-610DM7

12-YEAR WARRANTY COMPRESSOR
SWITCH ZONE
FRESHERTECHS



Technical specifications

Energy class	A++
Freezer star rating	**/**
Energy consumption (kWh/year)	343
Net capacity (l)*	610
Net refrigerator capacity (l)*	430
Net freezer capacity (l)	90
Net Switch Zone capacity (l)	90
Freezing power in 24h (kg)	10
Freezer autonomy in case of power cut (h)	18
Climate class	SN/N/ST
Noise level dB (A)	40
Dimensions (cm)	
Height	190
Width	90.8
Depth	73.8
Net weight (kg)	134
Gross weight (kg)	145

Features

- LED external control display
- Total No Frost
- ABT® (antibacterial technology)
- Switch Zone
- Dry & Humidity Zones
- Super Cooling
- Super Freezing
- Holiday function
- LED light
- Twist ice maker
- Day light
- Twist ice maker
- Ice cube tray(s)
- Egg tray(s)
- Adjustable feet (front/rear): 2/0
- Depth with open door: 1130mm
- Integrated handles

ACM / Black Stainless Steel
EAN - 6901018059704

HTF-452DM7

12-YEAR WARRANTY COMPRESSOR
A++ ENERGY CLASS
FRESHERTECHS



Technical specifications

Energy class	A++
Freezer star rating	**/**
Energy consumption (kWh/year)	303
Net capacity (l)*	452
Net refrigerator capacity (l)*	314
Net freezer capacity (l)	138
Freezing power in 24h (kg)	12
Freezer autonomy in case of power cut (h)	12
Climate class	SN/N/ST
Noise level dB (A)	40
Dimensions (cm)	
Height	190
Width	83.3
Depth	65.6
Net weight (kg)	106
Gross weight (kg)	119

Features

- LED external control display
- Total No Frost
- Dry & Humidity Zones
- Super Cooling
- Super Freezing
- Holiday function
- LED light
- Twist ice maker
- Ice cube tray(s)
- Egg tray(s)
- Adjustable feet (front/rear): 2/0
- Depth with open door: 1000mm
- Integrated handles

ACM / Black Stainless Steel
EAN - 6901018057076

HTF-452WM7

12-YEAR WARRANTY COMPRESSOR
FRESHERTECHS
WATER DISPENSER



Technical specifications

Energy class	A++
Freezer star rating	**/**
Energy consumption (kWh/year)	303
Net capacity (l)*	452
Net refrigerator capacity (l)*	314
Net freezer capacity (l)	138
Freezing power in 24h (kg)	12
Climate class	SN/N/ST
Noise level dB (A)	40
Dimensions (cm)	
Height	190
Width	83.3
Depth	65.6
Net weight (kg)	106
Gross weight (kg)	119

Features

- LED external control display
- Total No Frost
- Dry & Humidity Zones
- Super Cooling
- Super Freezing
- Holiday function
- LED light
- Twist ice maker
- Ice cube tray(s)
- Egg tray(s)
- Adjustable feet (front/rear): 2/0
- Depth with open door: 1000mm
- Integrated handles

ACM / Black Stainless Steel
EAN - 6901018060533

HB16FMAAA

A++ CLASS
EASY ACCESS DRAWER
TOTAL NO FROST



Technical specifications

Energy class	A++
Freezer star rating	**/**
Energy consumption (kWh/year)	387
Net capacity (l)*	424
Net refrigerator capacity (l)*	303
Net freezer capacity (l)	121
Freezing power in 24h (kg)	14
Freezer autonomy in case of power cut (h)	20
Climate class	SN-T
Noise level dB (A)	40
Dimensions (cm)	
Height	190
Width	70
Depth	67.5
Net weight (kg)	95
Gross weight (kg)	103

Features

- Dual Inverter, 12-year Warranty*
- Total No Frost
- LED external control display
- MyZone
- Super Cooling
- Super Freezing
- Top LED light
- Ice cube tray(s)
- Egg tray(s)
- Front adjustable feet
- Integrated handles

*2-year full warranty +10-year compressor only

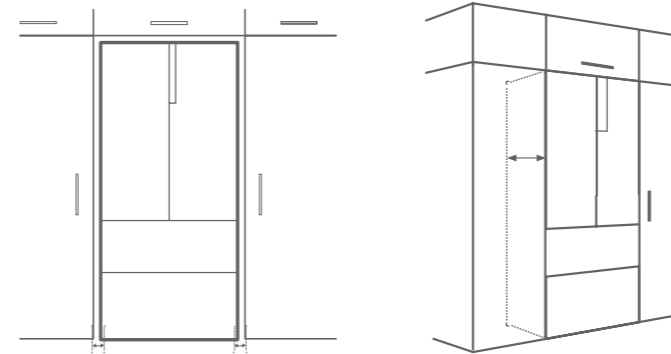

Stainless Steel
EAN - 6901018063855

HB18FGSAAA

12-YEAR WARRANTY COMPRESSOR
A++ CLASS
EASY ACCESS DRAWER



Technical specifications

Energy class	A++
Freezer star rating	**/**
Energy consumption (kWh/year)	298
Net capacity (l)*	508
Net refrigerator capacity (l)*	351
Net freezer capacity (l)	157
Freezing power in 24h (kg)	14
Freezer autonomy in case of power cut (h)	18
Climate class	SN-T
Noise level dB (A)	38
Dimensions (cm)	
Height	190
Width	83
Depth	67.5
Net weight (kg)	136
Gross weight (kg)	147

Features

- Dual Inverter, 12-year Warranty*
- Total No Frost
- LED external control display
- Humidity and dry zones
- ABT® (antibacterial technology)
- Super Cooling
- Super Freezing
- Fresher Sensors
- Fresher Pad
- Top LED light
- Twist Ice Maker
- Adjustable feet
- Integrated handles

*2-year full warranty +10-year compressor only

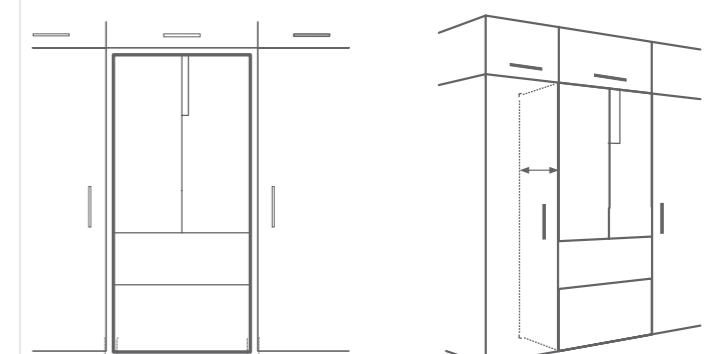

Glass Stainless Steel
EAN - 6901018064777



FREEZERS

Xx \ INSTASWITCH FREEZER

Xx \ Chest Freezers

Haier offers the latest advances in capacity, performance and convenience in its upright and horizontal freezers range.

Every detail of our freezers has been created to offer you maximum convenience while also delivering unrivalled performance. For example, the exclusive Easy Handle has been designed to ensure the effortless opening of our upright freezers, the majority of which are also highly adaptable, thanks to their convenient modular designs. The INSTASWITCH FREEZER, allows you to change the temperature inside the freezer from -26°C to 0°C and back again, according your needs at the time. Thanks to these features and a host of other thoughtful innovations that ensure your food stays fresh for longer, Haier has created smart cooling technology that truly works for you.

Cooling technology redefined.



INSTASWITCH FREEZER

THE BEST OF EVERY SEASON ALL YEAR LONG

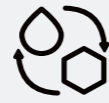

Everything about Haier's **INSTASWITCH FREEZER** has been designed for ultimate ease of use and optimum food conservation.



BIG CAPACITY

The INSTASWITCH FREEZER range now boasts 26% more storage capacity*, offering up to 330 litres. So not only are they more adaptable to your needs, but they also allow you to store more food than ever before!

*Tested in real conditions & compared with Haier upright freezer



EASY HANDLE. EFFORTLESS ACCESS TO AN INTELLIGENT INTERIOR.

The robust Easy Handle makes opening and closing the freezer door effortless, while the inner layout has been redesigned to better respond to everyday consumer needs, such as the new counter-door shelves to store small items that often get lost in freezer drawers.

FRESHER ZONE DRAWER.

SHOCK FREEZE OR QUICKCOOL IN AN INSTANT.

In freezer mode, the Fresher Zone drawer allows you to "Shock Freeze" your food items down to -26°C, which helps to lock in more nutrients and eliminate bacteria, keeping food fresher & healthier for longer. While in fridge mode, the QuickCool setting is activated, meaning the temperature of your food is kept steady at 0°C.



WI-FI CONNECTION. EVERYTHING UNDER CONTROL.

INSTASWITCH FREEZERS are all Wi-Fi connected so you can even control your freezer's temperature using your smartphone! You can also set up alerts to be informed of abnormal temperature rises provoked by an open door or an electricity power cut, for example.

H3F-280WSAAU1

BIG CAPACITY
FRESHER ZONE
WI-FI



Technical specifications

Energy class	A++
Freezer star rating	*/***
Energy consumption (kWh/year)	260
Net freezer capacity (l)	285
Freezing power in 24h (kg)	19
Freezer autonomy in case of power cut (h)	16
Climate class	SN-T
Noise level dB (A)	38
Dimensions (cm)	
Height	170
Width	59.5
Depth	67
Net weight (kg)	77
Gross weight (kg)	86.4

Features

- Total No Frost
- LED external control display
- Interior LED Light
- Door Opening Alarm
- Big Capacity
- Fresher Zone (Shock Freeze/Quick Cool)
- Super Cooling
- Super Freezing
- Convertability from Freezer to Fridge
- Wi-Fi
- Ice cube tray(s)
- Adjustable front feet
- Reversible door
- Easy Handle

White
EAN - 6930265384277

H3F-320WSAAU1

BIG CAPACITY
FRESHER ZONE
WI-FI



Technical specifications

Energy class	A++
Freezer star rating	*/***
Energy consumption (kWh/year)	285
Net freezer capacity (l)	330
Freezing power in 24h (kg)	21
Freezer autonomy in case of power cut (h)	16
Climate class	SN-T
Noise level dB (A)	38
Dimensions (cm)	
Height	190
Width	59.5
Depth	67
Net weight (kg)	80
Gross weight (kg)	91.8

Features

- Total No Frost
- LED external control display
- Interior LED Light
- Door Opening Alarm
- Big Capacity
- Fresher Zone (Shock Freeze/Quick Cool)
- Super Cooling
- Super Freezing
- Convertability from Freezer to Fridge
- Wi-Fi
- Ice cube tray(s)
- Adjustable front feet
- Reversible door
- Easy Handle

White / Stainsteel Look
EAN - 6930265384307

H3F-320WTAAU1

A+++ ENERGY CLASS
FRESHER ZONE
WI-FI



Technical specifications

Energy class	A+++
Freezer star rating	*/***
Energy consumption (kWh/year)	285
Net freezer capacity (l)	330
Freezing power in 24h (kg)	21
Freezer autonomy in case of power cut (h)	16
Climate class	SN-T
Noise level dB (A)	38
Dimensions (cm)	
Height	190
Width	59.5
Depth	67
Net weight (kg)	80
Gross weight (kg)	91.8

Features

- Total No Frost
- LED external control display
- Interior LED Light
- Door Opening Alarm
- Big Capacity
- Fresher Zone (Shock Freeze/Quick Cool)
- Super Cooling
- Super Freezing
- Convertability from Freezer to Fridge
- Wi-Fi
- Ice cube tray(s)
- Adjustable front feet
- Reversible door
- Easy Handle

White
EAN - 6930265384314

CHEST FREEZERS

UNRIVALLED CAPACITY. RESPONSIBLE CONSUMPTION.

Haier chest freezers offer great storage capacity (from xx to xxx litres) combined with an A+ energy consumption rating.



SUPER-FREEZE FUNCTION

Thanks to this function, your food quickly reaches a frozen state, preserving all of its nutritional properties and flavours.

AUTONOMY

If there's a power cut, no need to worry! Haier freezers maintain their original temperature for up to 35 hours without being connected to the mains*.

*Consult the relevant information for each model.

MICROCELLULAR FOAM INTERIOR

The innovative spirit at Haier demands the use of the latest materials in order to provide our customers with exclusive advantages. For that reason, Haier freezers have a galvanised aluminium interior injected with microcellular foam. The aluminium not only makes cleaning easier, but also noticeably lengthens the product's life, while the foam's insulating properties ensure an A+ energy rating.

LARGE HANDLES AND REINFORCED HINGES

The size of the handles on our freezers has been increased to offer the greatest possible comfort, while the special hinge system guarantees superior strength to that offered by traditional freezers, thereby providing stronger, longer-lasting chests.



INTERIOR LIGHT

Haier's innovative interior illumination system ensures enhanced visibility when restocking or removing food.



HORIZONTAL CONTROL PANEL

New display for easy temperature control.

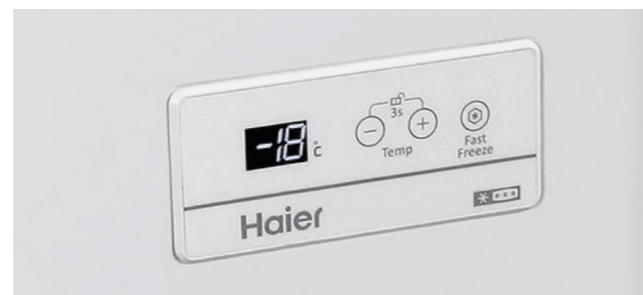

HCE319R

A+ ENERGY CLASS
ALUMINIUM INTERIOR
BALANCED LID



A+

Technical specifications

Energy class	A+
Freezer star rating	*/***
Energy consumption (kWh/year)	274
Net freezer capacity (l)	319
Freezing power in 24h (kg)	21
Freezer autonomy in case of power cut (h)	
Climate class	SN-T
Noise level dB (A)	43
Dimensions (cm)	
Height	84.5
Width	110
Depth	74.5
Net weight (kg)	51
Gross weight (kg)	58

Features

- Electronic control
- 2 metal baskets
- Textured aluminum interior finish
- Temperature failure indicator
- Balanced lid
- Manual defrosting
- Interior light

White
EAN - 6930265364651

HCE429R

A+ ENERGY CLASS
ALUMINIUM INTERIOR
BALANCED LID



A+

Technical specifications

Energy class	A+
Freezer star rating	*/***
Energy consumption (kWh/year)	333
Net freezer capacity (l)	429
Freezing power in 24h (kg)	28
Freezer autonomy in case of power cut (h)	
Climate class	SN-T
Noise level dB (A)	49
Dimensions (cm)	
Height	84.5
Width	141
Depth	74.6
Net weight (kg)	67
Gross weight (kg)	76

Features

- Electronic control
- 2 metal baskets
- Textured aluminum interior finish
- Temperature failure indicator
- Balanced lid
- Manual defrosting
- Interior light

White
EAN - 6930265371789

HCE519R

A+ ENERGY CLASS
ALUMINIUM INTERIOR
BALANCED LID



A+

Technical specifications

Energy class	A+
Freezer star rating	*/***
Energy consumption (kWh/year)	385
Net freezer capacity (l)	519
Freezing power in 24h (kg)	32
Freezer autonomy in case of power cut (h)	
Climate class	
Noise level dB (A)	SN-T
Dimensions (cm)	
Height	84.5
Width	165
Depth	74.7
Net weight (kg)	76
Gross weight (kg)	86

Features

- Electronic control
- 2 metal baskets
- Textured aluminum interior finish
- Temperature failure indicator
- Balanced lid
- Manual defrosting
- Interior light

White
EAN - 6930265374377



WINE COOLERS

Xx \ Wine Coolers

Keep your most prized treasures in optimal conditions with Haier wine coolers. The finest way to enjoy your passion in all its purity.

The painstaking design and advanced features of Haier's wine coolers have made them market leaders. Thanks to their low vibration compressor, they operate in complete silence. In addition, they incorporate innovative carbon filter technology to eliminate any possible smells, and efficient humidity and temperature controls to store your wines in perfect conditions.

Your wines are your treasured possessions. Treat them with the care they deserve.



WINE COOLERS

SMART STORAGE FOR FINE WINES.

Wine is highly sensitive to vibrations and noise. For that reason, the compressor in our wine coolers is equipped with a system to neutralise both problems, preserving your wine in optimal conditions. Furthermore, they are designed to work silently, reaching an imperceptible noise level of just 38 dB(A).



ANTI-UV GLASS

Sunlight and, above all, ultraviolet light, can cause chemical reactions that distort the colour and structure of your wine. To protect your prized collection, an anti-UV filter has been incorporated into the glass door of your Haier wine cooler.

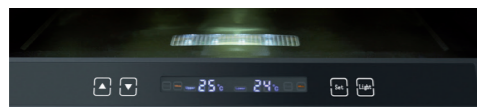

The **LED lighting** not only saves energy, but also doesn't produce heat. Its illumination, cold and uniform, guarantees first-rate care for your bottles of wine. Thanks to the **Double Zone** technology, the cooler offers you two distinct compartments in which the temperature can be controlled independently. In this way, you are able to conserve both your white and red wines at the same time.



HUMIDITY AND TEMPERATURE CONTROL. EXCEPTIONAL CARE FOR ALL YOUR WINES.

To keep your wines in the best state of conservation, Haier wine coolers have a humidity control system, maintaining it between 50-80%. They also keep temperature constant in order to preserve your wine collection in its purest state.



CARBON FILTER

Our wine coolers are fitted with an active carbon filter that acts as a barrier to external odours. This is especially important if the wine cooler is located in the kitchen. Thanks to this filter, the wine ages in an environment that most closely resembles a natural stone wine cellar.

WS30GA

A ENERGY CLASS
LED DISPLAY
NO VIBRATION COMPRESSOR

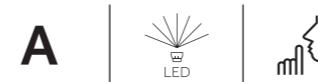
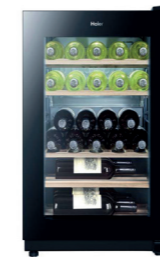

Technical specifications

Energy class	A
Energy consumption (kWh/year)	133
Net capacity	104
Gross capacity	108
Climate class	N
Noise level dB(A)	38
Temperature range (from>to)	6-18
Number of bottles	30
Dimensions (cm)	
Height	82
Width	50
Depth	54
Net weight (kg)	37

Features

- Control panel interior
- LED display
- LED temperature alarm
- Anti-vibration compressor
- Anti-UV glass door
- Electrical adjustable thermostat
- Automatic defrosting
- Hinged (right / not reversible)
- 4 Wood shelves
- 2 front adjustable feet
- Lockable

Black glass
EAN - 6930265355581

WS50GA

A ENERGY CLASS
LED DISPLAY
NO VIBRATION COMPRESSOR

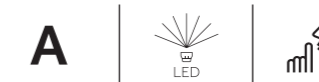
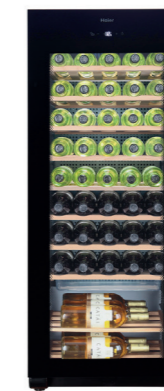

Technical specifications

Energy class	A
Energy consumption (kWh/year)	146
Net capacity	167
Gross capacity	169
Climate class	ST
Noise level dB(A)	42
Temperature range (from>to)	5-20
Number of bottles	50
Dimensions (cm)	
Height	127
Width	50
Depth	54
Net weight (kg)	58
Depth with open door	106

Features

- Control panel exterior
- LED display
- LED temperature alarm
- Anti-vibration compressor
- Anti-UV glass door
- Carbon filter
- Electrical adjustable thermostat
- Automatic defrosting
- Evaporator cover
- Hinged (right / not reversible)
- 10 Wood shelves
- 2 front adjustable feet
- Lockable

Black glass
EAN - 6930265346299

WS53GDA

A ENERGY CLASS
LED DISPLAY
DUAL ZONE



Technical specifications

Energy class	A
Energy consumption (kWh/year)	TBD
Net capacity	162
Gross capacity	164
Climate class	ST
Noise level dB(A)	42
Temperature range (from>to)	6-18
Number of bottles	49
Dimensions (cm)	
Height	127
Width	50
Depth	54
Net weight (kg)	58
Depth with open door	106

Features

- Control panel interior
- LED display
- LED temperature alarm
- Dual zone
- Anti-vibration compressor
- Anti-UV glass door
- Carbon filter
- Electrical adjustable thermostat
- Automatic defrosting
- Evaporator cover
- Hinged (right / not reversible)
- 9 Wood shelves
- 2 front adjustable feet
- Lockable

Black glass
EAN - 6930265380422



WASHING

Xx \ Washing Machine

Xx \ Washer-Dryer

Xx \ Dryer

Haier washing machines are a benchmark in efficiency, silent operation and durability.

Haier is a world leader in washing, with an extensive range that can fulfil the needs of any home. Our innovative products range from washing machines that provide professional results such as the Super Drum, to unique double-drum systems, like the one in the Haier Duo and Duo Dry series, that allows you to perform two independent washes at the same time. All of Haier's washing machines include the Direct Motion (direct to drum) motor, with its incomparable performance. Not only is it one of the quietest on the market (only 66 dB(A) at maximum spin), it also has one of the highest possible energy saving ratings (up to A+++ -50%). It's incredibly durable, too - each motor comes with a lifetime warranty included. All models also feature the exclusive ABT® (antibacterial treatment), to ensure a completely hygienic and healthy wash.

Choose the best for your clothes with a Haier washing machine.



DIRECT MOTION TECHNOLOGY

LESS NOISE. MORE FREEDOM.

With the **Haier Direct Motion** motor and its silent, vibrationless spin mode at only 66 dB(A), you'll no longer be disturbed by unnecessary noise, so you can enjoy the moments that really matter.



LIFETIME WARRANTY



DIRECT MOTION

Haier's **Direct Motion motors** are truly a leap forward in washing machine technology. By using less individual components than standard motors, the Direct Motion motor is significantly more reliable, efficient and quiet.

The absence of a belt between the motor and the drum (= "direct motion") means there are fewer parts, leading to significantly increased reliability - not to mention less potential for noisy vibrations (only 66 dB(A)) and incredible energy savings (up to A+++ -50%)!

And as the **World's number 1 brand for home laundry appliances***, the reliability of Haier's Direct Motion motors means that they'll last a lifetime - a worthwhile investment!

*Source Euromonitor International Limited. Consumer Appliances 2019ed. % unit share, 2018 data. Major Appliances category is the sum of dishwashers, home laundry appliances, large cooking appliances, microwaves and refrigeration appliances.



MINIMUM NOISE

Removal of drive belt means less vibration = LESS NOISE. Reaching up to 66 dB(A) in spin mode, it's two times quieter than standard motors.*

* A 3 dB(A) decrease is equivalent to two times of the noise reduction.

A+++ -50%

MAXIMUM PERFORMANCE

Super efficient beltless drive saves energy, with an A+++ rating improving energy use by up to -50%.

Available on: **Duo Dry / Easy Touch / 876 / Hatrium Series**



LIFETIME WARRANTY

The most reliable thanks to Haier's unique knowledge and production methods. 4 MILLION motors are produced each year!

INVERTER MOTOR

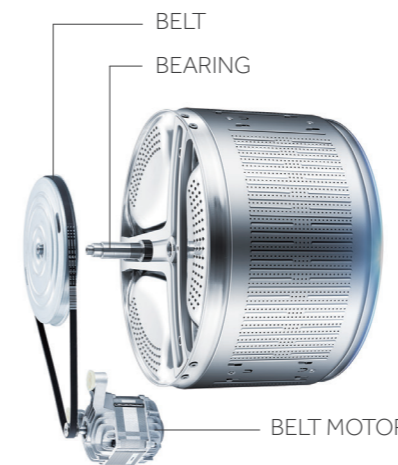

Inverter motor



DIRECT MOTION MOTOR

1:12 | 1:1
DRIVE RATIO

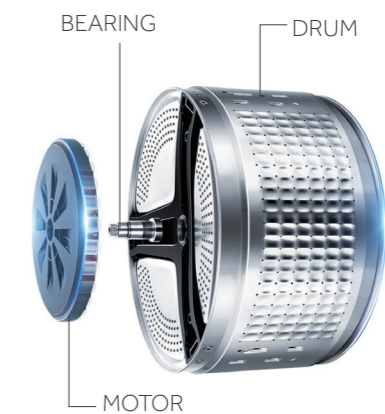

Direct motion

SUPER DRUM

PROFESSIONAL RESULTS RIGHT IN YOUR HOME

If you're looking for professional-level results, look no further than the **Haier Super Drum**. Get more laundry done in less time thanks to the impressive combined 10 kg washing and 6 kg drying capacity. You'll also save on energy costs, thanks to the highly efficient Direct Motion motor and convenient preset programmes that allow you to quickly select and adjust wash cycles according to your needs. With a touchscreen interface and 45 cm-wide porthole that makes loading larger garments easier, the Super Drum is the machine that gives you much more for less!

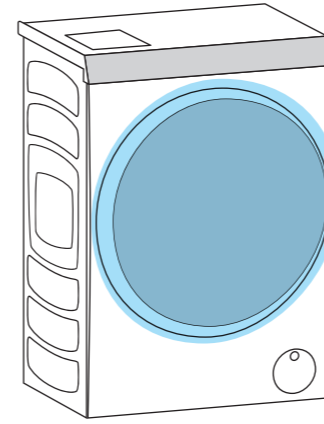

I-REFRESH

The Haier Super Drum includes brand new micro vapour technology that cleans your clothes in a highly effective and innovative manner, removing odours and reducing wrinkles without any direct contact with water!



XXL DRUM SIZE ENABLES BIG WASHING CAPACITY

Thanks to its large diameter (601 mm), the mechanical power of the drum's movement is enhanced, allowing detergent to penetrate more effectively. Add to this the 'pillow' design of the drum's interior that ensures your clothes are protected from any damage during the cycle, and you have a washing performance enhanced in more ways than one.

XXL

MY TIME

Haier's clever 'My Time' function allows you to fine tune the duration of your wash according to your needs, so you can shorten or lengthen the time - even during the cycle!



DIRECT MOTION MOTOR WITH A LIFETIME WARRANTY

The drum is driven by its own patented Direct Motion motor, meaning high performance at minimum noise levels, low energy consumption and unparalleled durability.



Intuitive user interface

Control all your washer-dryer functions via the seamlessly integrated LCD touch screen. This stunning display allows you to choose from 14 different preset programmes in multiple languages.



What's more, the interface can also be **controlled remotely via a smartphone or tablet with a Wi-Fi connection**. In this way, you can easily:

- Monitor the washing/drying cycle's progress
- Get perfect cycle recommendations from smart wash
- Personalise and save your most-used wash cycles



The unique **Stains Treatment** helps you to get rid of stubborn stains such as grass, wine, juice, milk, blood or soil.

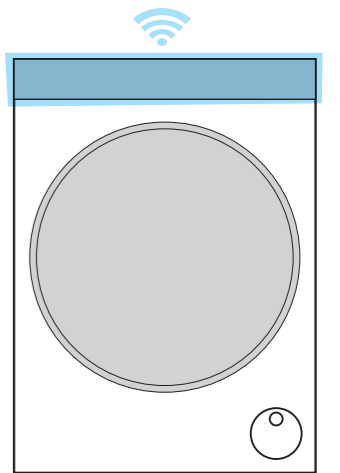

AMAZON DASH REPLENISHMENT



The Haier Super Drum is enabled with Amazon Dash Replenishment. This handy function from the Amazon Dash Service tracks your laundry activity and automatically orders replacement detergent & softener to arrive at your door before you run out! Choose from a variety of brands via the digital display and let the Super Drum take care of the rest.



Smart Dosing

The Super Drum's intelligent Smart Dosing feature will help you to use the exact amount of detergent and softener necessary for each of your washes, depending on the weight and cleaning programme requirements. This clever system can help you save the equivalent of up to 33 cycles a year in products!



Pillow Drum design

The drum's surface is illuminated and features a special design with small pillows and a laser welded drum without any asperities to guarantee maximum care for your fabrics when the washing machine is operating.



Haier ABT® exclusivity

The detergent drawer & door gasket receives a special treatment to keep clothes free from bacteria (99.8 %) and has been **officially certified by VDE**.

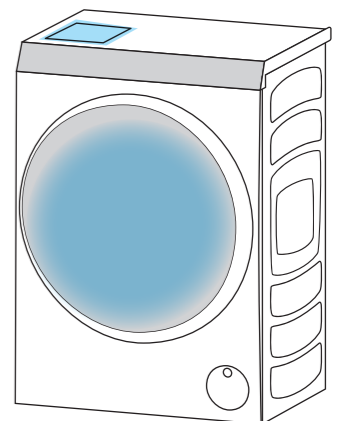

SUPER DRUM
WASHING

WASHING
SUPER DRUM

DUO DRY

AN EXTRA DRUM TO SAVE EXTRA TIME

Discover a completely new washing experience with **Haier Duo Dry**. The first washer-dryer machine in the world with an exclusive double-drum system that can perform two independent washing cycles simultaneously. Whites and colours, wool and cotton... no more waiting around for each load to finish before starting on the next! You can even switch the larger drum to drying mode to wash & dry simultaneously.

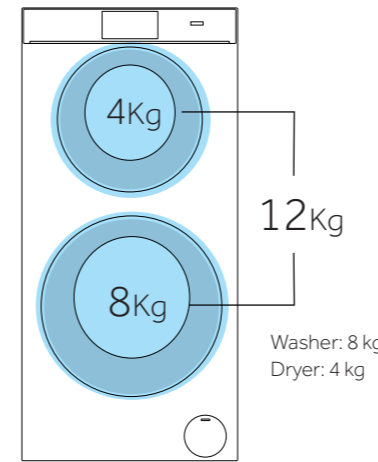

Extra drum. Extra time.

With the Haier Duo Dry, you can wash up to 12 kg of clothes simultaneously thanks to the combined capacity of the 4 kg in upper drum and 8 kg lower drum. You may also use one drum at a time, just like a regular wash, or use the upper drum to wash and the lower drum to dry, depending on your needs at the time. It truly is the washing machine that offers maximum convenience in the minimum amount of time.

Auto Weight

The washing machine adapts water & energy consumption and cycle duration according to the quantity of laundry.

XXL



TWO DIRECT MOTION MOTORS WITH A LIFETIME WARRANTY

Each drum is driven by its own Direct Motion motor: high performance, low consumption and great durability.



Intuitive user interface

Control all your washer-dryer functions via the innovative 7" TFT touch screen, available in multiple languages, and choose from the 21 (lower drum) and 13 (upper drum) brilliant programmes.



The interface can also be **controlled remotely from a smartphone or tablet with a Wi-Fi connection**. In this way, you can easily:

- Monitor the washing/drying cycle's progress
- Get perfect cycle recommendations from smart wash
- Personalise and save your most-used wash cycles



The unique **Stains Treatment** helps you to get rid of stubborn stains such as grass, wine, juice, milk, blood or soil.

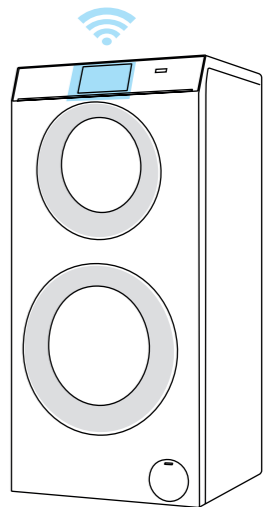

A

A ENERGY RATING

Save on your energy bill with the Duo Dry. Now you can enjoy an optimum, sustainable and efficient wash with low energy consumption.

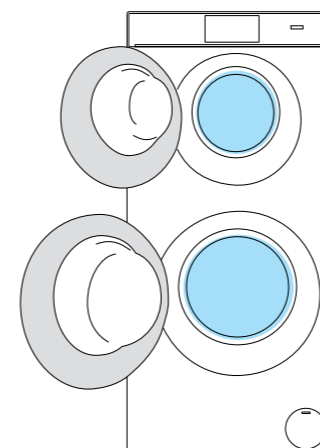

Pillow Drum design

The drum's illuminated inner surface features a special 'pillow'-shaped pattern as well as laser welding in order to eliminate imperfections and guarantee the maximum care for your fabrics during every wash cycle.



Haier ABT® exclusivity

The detergent drawer & door gasket has been given a special treatment that helps keep clothes free from bacteria (99.8%) with **official certification from VDE**.



EASY TOUCH

INTUITIVE IN NATURE

The **Easy Touch** digital touch display makes using your washing machine faster & easier than ever: simply use your finger to find a programme, select the one you need and you're ready to go! With the U+ app you can control Easy Touch from your phone, so now you can check your cycle whenever you want, wherever you are. You can even access Amazon Dash Auto Replenishment for easy automatic re-ordering of detergent and softener. The 12 kg capacity standard 60 cm size and ultra-efficient Direct Motion motor also means less cycles overall = lower energy bills!

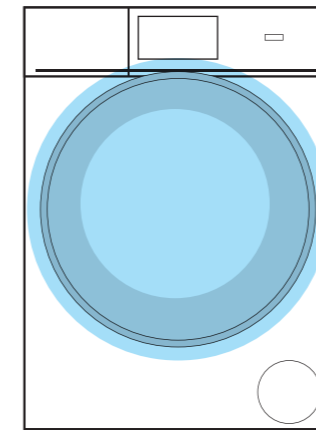

XL Drum

Drum diameter reaches 525 mm in a standard size washing machine. Thanks to its larger diameter, it gives you enhanced washing efficiency and more care for your clothes with less wrinkles.



Steam function

Steam is diffused inside the drum with detergent, relaxing the fibres to remove the stubborn dirt within the material of your laundry.



Energy rating

The A+++ energy rating represents a 50% energy saving compared to a standard A rating washing machine.

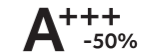

DIRECT MOTION MOTOR WITH A LIFETIME WARRANTY

The drum is driven by its own Direct Motion motor, meaning high performance, low energy consumption and great durability.



Intuitive user interface

Control all your washing machine functions via the innovative 7" TFT touch screen, available in multiple languages, and choose from the 23 brilliant programmes.

The interface can also be **controlled remotely from a smartphone or tablet with a Wi-Fi connection**. In this way, you can easily:

- Monitor the washing cycle's progress
- Get perfect cycle recommendations from smart wash
- Personalise and save your most-used wash cycles



The unique **Stains Treatment** helps you to get rid of stubborn stains such as grass, wine, juice, milk, blood or soil.

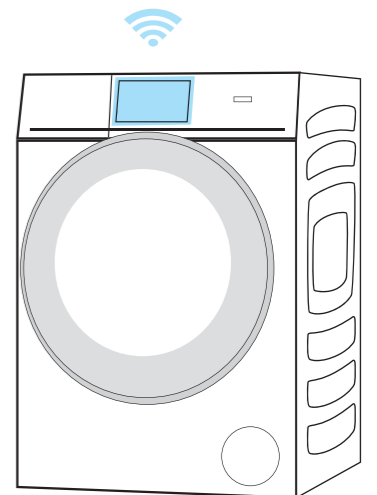

AMAZON DASH REPLENISHMENT



The Haier Easy Touch is enabled with Amazon Dash Replenishment. This handy function from the Amazon Dash Service tracks your laundry activity and automatically orders replacement detergent & softener to arrive at your door before you run out! Choose from a variety of brands via the digital display and let the Easy Touch take care of the rest.

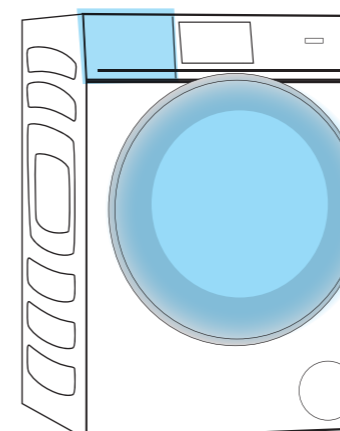

Smart Dosing

Use the exact amount of detergent and softener necessary in each wash. This clever system can help you save the equivalent of up to 33 cycles a year in products!



Pillow Drum design

The drum's surface is illuminated and features a special design with small pillows and a laser welded drum without any asperities to guarantee maximum care for your fabrics when the washing machine is operating.



Haier ABT® exclusivity

The detergent drawer & door gasket receives a special treatment to keep clothes free from bacteria (99.8%) and has been **officially certified by VDE**.



SERIES 876

WHEN SILENCE SPEAKS FOR QUALITY

The **Haier 876 Series** washer and dryer answer all of your laundry needs in one perfect couple. The ultra-quiet washing machine and its elegant drying partner not only take care of your laundry from A to Z, but their complementary designs make them stylish addition to any home.



XL DRUM: BIG CAPACITY IN STANDARD SIZE

The Haier 876 Series boasts an impressive drum size of 525 mm (usual size = 495 mm), while still being a standard 60 cm washing machine. Its innovative design makes maximum use of space so you can get more washing done without having to find more room in your home for a larger machine. XL washing loads in a standard size.



A SILENT PARTNER

The Haier 876 Series is easily one of the quietest washing machines on the market*, making only 66 dB(A) of noise! So now you can get your laundry done without disturbing the neighbours... or yourself!

*In spinning mode. Based on decibel level measurement less than -3 dB(A) is equivalent to 50% of initial power.

GOOD THINGS COME IN SMALL PACKAGES

Not only does the Haier 876 Series allow you to get more washing done in a standard-size machine, it can also fit into even the smallest of spaces thanks to its ultra-slim design. Managing to accommodate an impressive 8 kg of laundry, the slim depth of the machine (46 cm) means it can fit easily into any home.



WIDE TOUCH SCREEN

The beautifully designed touch-control widescreen display allows you to choose your programme with just one touch for ultimate ease of use.

HW80-B14876

ULTRA SILENCE
XL DRUM
LIFETIME WARRANTY MOTOR

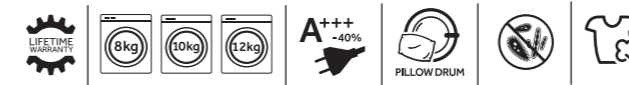

Technical specifications

Energy class	A+++ -40%
Spinning efficiency class	B
Washing capacity (kg)	8/10/12
Maximum spinning speed (rpm)	1400
Spinning speed (rpm)	400-1400
Energy consumption (kWh/yr)	TBD
Water consumption (l/yr)	TBD
Noise level dB(A) washing/spinning	66
Glass door diameter (cm)	TBD
Dimensions (cm)	
Height	85
Width	59.5
Depth	46*
Net Weight (kg)	72
Gross Weight (kg)	75

Features

- Touch control
- ABT® (antibacterial treatment)
- Electronic washing management
- Steam
- Direct Motion motor
- Ultra Silence
- XL drum
- Auto weight
- Smart dual spray
- Drum light
- Auto Lock Door
- Automatic regulation of water consumption
- Door cover
- Adjustable feet
- Aquastop
- 16 programmes
- End Delay (0.5-24h)
- Memo Function

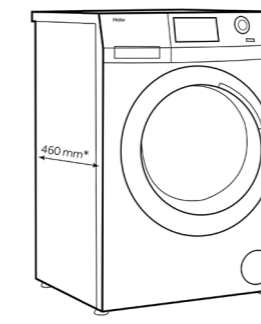
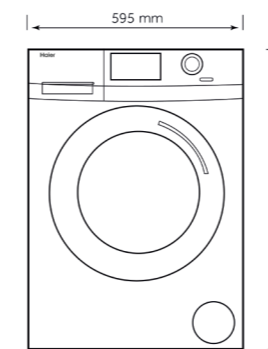

*600 mm for the 10 & 12kg

White
EAN - TBD

HD90-A876

HEAT PUMP
TOUCH SCREEN CONTROL
REVERSE DRUM ACTION



Technical specifications

Energy class	A
Drying capacity (kg)	9
Energy consumption (kWh/yr)	TBD
Water consumption (l/yr)	TBD
Noise level dB(A) washing/spinning	TBD
Glass door diameter (cm)	TBD
Dimensions (cm)	
Height	85
Width	59.5
Depth	46
Net Weight (kg)	72
Gross Weight (kg)	75

Features

- Heat Pump Dryer
- ABT® (antibacterial treatment)
- Touch screen control
- 16 Programmes
- Reverse drum action
- Drum light
- Refresh Programme
- 4 Dryness settings

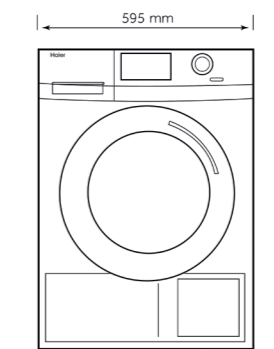

White
EAN - TBD

HWD120-B1558U

DOUBLE DRUM
TWO DIRECT MOTION MOTORS
TFT TOUCH SCREEN 7" - WI-FI

Haier **DUO DRY**

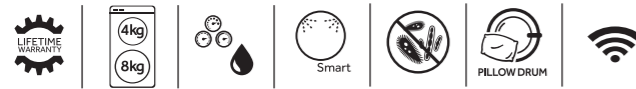

Technical specifications

Energy class	A
Washing capacity (kg)	12
Drying capacity (kg)	4
Maximum spinning speed (rpm)	1500
Spinning speed (rpm)	400-1500
Noise level dB(A) washing/spinning	55/70
Glass door diameter (cm)	Upper 23.5 Lower 32
Dimensions (cm)	
Height	128
Width	60
Depth	60
Net Weight (kg)	121
Gross Weight (kg)	130

Features

- 7" TFT Display
- Electronic washing management
- Touch button
- Direct Motion motor(s)
- Auto weight
- ABT® (antibacterial treatment)
- Smart Dual Spray
- Drum Light
- Auto Lock Door
- Automatic regulation of water consumption
- Door cover
- Adjustable feet
- Aquastop
- Special stains treatment
- End Delay (0.5-24h)
- Memo Function



White
EAN - TBD

HW120-B1558

DOUBLE DRUM
A+++ -30% ENERGY CLASS
TWO DIRECT MOTION MOTORS

Haier **DUO**



Technical specifications

Energy class	A+++
Spinning efficiency class	B
Washing capacity (kg)	12
Maximum spinning speed (rpm)	1500
Spinning speed (rpm)	400-1500
Energy consumption (kWh/yr)	198
Water consumption (l/r)	11840
Noise level dB(A) washing/spinning	50/70
Glass door diameter (cm)	Upper 23.5 Lower 32
Dimensions (cm)	
Height	128
Width	60
Depth	60
Net Weight (kg)	116
Gross Weight (kg)	128

Features

- 7" TFT Display
- Electronic washing management
- Touch button
- Direct Motion motor(s)
- Auto weight
- ABT® (antibacterial treatment)
- Smart Detecting
- Smart Dual Spray
- Drum Light
- Auto Lock Door
- Automatic regulation of water consumption
- Adjustable feet
- Aquastop
- Special stains treatment
- End Delay (0.5-24h)
- Memo Function

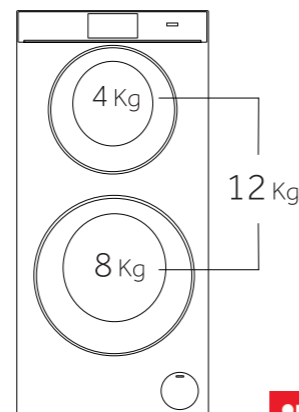

White
EAN - TBD

HW80-B14636

A+++ -50%
DIRECT MOTION MOTOR
67 DB(A)

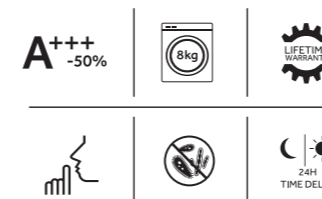

Technical specifications

Energy class	A+++ -50%
Spinning efficiency class	B
Washing capacity (kg)	8
Maximum spinning speed (rpm)	1400
Spinning speed (rpm)	400-1400
Energy consumption (kWh/yr)	97
Water consumption (l/yr)	11500
Noise level dB(A) washing/spinning	56/67
Glass door diameter (cm)	32
Dimensions (cm)	
Height	85
Width	59.5
Depth	55
Net Weight (kg)	72
Gross Weight (kg)	76

Features

- LED Display
- Electronic washing management
- Direct Motion motor
- Auto weight
- ABT® (antibacterial treatment)
- Smart Opening
- Auto Lock Door
- Automatic regulation of water consumption
- Door cover
- Adjustable feet
- End Delay (0.5-24h)

White
EAN - TBD

HW90-B14636

A+++ -50%
DIRECT MOTION MOTOR
67 DB(A)



Technical specifications

Energy class	A+++ -50%
Spinning efficiency class	B
Washing capacity (kg)	9
Maximum spinning speed (rpm)	1400
Spinning speed (rpm)	400-1400
Energy consumption (kWh/yr)	TBD
Water consumption (l/yr)	TBD
Noise level dB(A) washing/spinning	57/67
Glass door diameter (cm)	32
Dimensions (cm)	
Height	85
Width	59.5
Depth	55
Net Weight (kg)	72
Gross Weight (kg)	75

Features

- LED Display
- Electronic washing management
- Direct Motion motor
- Auto weight
- ABT® (antibacterial treatment)
- Auto Lock Door
- Automatic regulation of water consumption
- Door cover
- Adjustable feet
- End Delay (0.5-24h)

White
EAN - TBD

HW100-B14636

A+++ -50%
DIRECT MOTION MOTOR
67 DB(A)

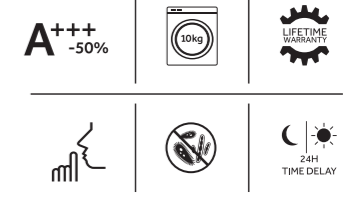

Technical specifications

Energy class	A+++ -50%
Spinning efficiency class	B
Washing capacity (kg)	10
Maximum spinning speed (rpm)	1400
Spinning speed (rpm)	400-1400
Energy consumption (kWh/yr)	140
Water consumption (l/yr)	12000
Noise level dB(A) washing/spinning	56/67
Glass door diameter (cm)	32
Dimensions (cm)	
Height	85
Width	59.5
Depth	55
Net Weight (kg)	74
Gross Weight (kg)	77

Features

- LED Display
- Electronic washing management
- Direct Motion motor
- Auto weight
- ABT® (antibacterial treatment)
- Auto Lock Door
- Automatic regulation of water consumption
- Door cover
- Adjustable feet
- End Delay (0.5-24h)

White
EAN - TBD

GLOSSARY

COOLING

ABT **ABT® antibacterial technology**
Exclusive technology which prevents the formation of bacteria throughout the whole air flow of Haier refrigerators for optimum conservation of foods*.
* Consult models.

Anti-fingerprint protection
Special treatment applied to household appliances with a stainless steel finish, to stop fingerprints leaving a mark when hands are passed over the surface.

Easy Access
Sliding drawer design for rapid, easy and convenient access to the inside of the freezer section of Haier Combis and French Door models.

Fresher Techs®
All of Haier's innovative and exclusive technologies (Fresher Pad, Fresher Sensors, Fresher Zones and Fresher Filters) to keep foods as fresh as possible for as long as possible.

Humidity & Dry Zones
Indicates that the model has two special drawers: one with high humidity (up to 90%) and the other with low humidity (less than 45%).

Inverter Compressor with a 12-year warranty
A quieter and more efficient inverter compressor, with complete peace of mind thanks to Haier's exclusive extended 10-year* warranty.
* Consult models.

LED lighting
Allows perfect viewing with lower consumption and greater durability than conventional lighting.

Lifetime warranty for the compressor
Special compressor warranty for the whole useful life of the device*. Consult terms and conditions on the warranty card or at www.haier.com
* Model HB26FSSAAA.

MyZone
Flexible storage area, with temperature regulation and 3 innovative functions: QuickCool, Chiller or Fruit & Vegetables.

Quiet operation
Products with this label guarantee effective operation with a practically imperceptible noise level: Combis (38 dB(A))

Switch Zone
Independent and ultra-flexible area which can operate as a refrigerator or freezer. The temperature can be regulated from -20°C to +5°C.

Total No Frost
Prevents the formation of frost in the freezer and distributes cold better throughout the refrigerator for easy maintenance.

VDE quality seal
World reference seal awarded by the prestigious Testing and Certificate Institute of the German Federation of Electrotechnical, Electronic and Information Technologies Industries to products* with the highest international quality.
* Model A2FE735CXJ.

XL XL Capacity
Differentiates the larger capacity Haier products: Side by Side (up to 685 L), Combis Gen 3 (up to 436 L)

GLOSSARY

WASHING

ABT® antibacterial treatment
Exclusive Haier material which protects the most sensitive areas of washing machines (detergent drawer and drum) and tumble driers (water tank and filter) from the formation of mould and bacteria for a more hygienic and healthy result.

A+++ -50% Energy class
Determines its electricity consumption. It is measured on a scale of values from D (the least efficient) to A+++ -50% (most efficient). Haier is a member of the European Energy+ organisation, which groups together all manufacturers of class A+ devices.

Lifetime warranty in the Direct Motion motor
Washing machine models with this logo have a special lifetime warranty for the Direct Motion motor. Consult terms and conditions on the warranty card or at www.haier.com

Load capacity
This is the maximum load capacity for cotton clothes, which guarantees compliance with energy efficiency, wash and spin effectiveness.

Pillow Drum
Indicates that the inside of the washing machine drum has a special design with small pads to protect clothes during the wash.

Smart Detecting
Water hardness varies from home to home. A smart detection system, in combination with Smart Dosing technology, ensures you will always get the perfect wash.

Smart Dosing
Smart Dosing helps you to use the exact amount of detergent and softener necessary for each of your washes, saving the equivalent of up to 33 cycles a year in cleaning products.

Smart Dual Spray
Automatic cleaning system for the washing machine which is activated at the end of the wash cycle.

Stains Treatment
Stains Treatment helps you to get rid of embedded stains such as blood, grass, wine, juice, milk blood or soil.

24h time delayed end
Select when you want the program to finish, and the washing machine will calculate automatically the start time.

Haier has a policy of ongoing technological development with considerable investment in research and development. For this reason, the characteristics and the design of the products may vary compared to the details published in this catalogue.